

**A LATHE IS REQUIRED FOR INSTALLATION OF THIS KIT. THIS IS AN ADVANCED INSTALLATION! See the last page of these instructions to view the modification of the stock damping rods.**

## **GOLD VALVE INSTALLATION**

### **KTM 50 SX 31mm BPF**

Fk Code

<IP FMGV 3102C.doc> **FMGV 3102C** P Thede © 6.3.16

**TOOLS & SUPPLIES REQUIRED:** (In addition to those required for fork disassembly.) **LATHE**, In-lb Torque Wrench that accurately measures 0 to 50 in-lbs (0.58 kgf-m), Metric Calipers, 0-25 mm Metric Micrometer, Loctite (included), TPSH 1225 (included), USF05 Suspension Fluid, Propane Torch, TMPS 02 Pin Spanner or TFCH PS24050 Seal Head Tool, **M9x1.0 bottoming tap**.

**NOTE:** In stock form both forks are identical internally. When this modification is completed the compression leg will create only compression damping, while the rebound leg will create only rebound damping.

## **DISASSEMBLY - BOTH LEGS**

- D1 **CLEANLINESS IS CRITICALLY IMPORTANT.** Completely disassemble and clean your front forks. If you are unfamiliar with this process, STOP!!!! Do not proceed. Seek out a qualified suspension technician to complete the installation.
- D2 Remove the Fork Cap, Jam Nut and Bottom-out Spacer.
- D3 Gently pry off the Dust Seal. This will expose the Seal Clip. Remove the Seal Clip with a small screwdriver (the stock clip can be a pain as on some of them one end is tapered in and one tapered out, find the "easy-to-grab-with-a-small-screwdriver-or-clip-tool-end"). Slide hammer off the Outer Tube (this may bend the Seal Washer – don't worry, see Assembly).
- D4 Remove the Seal Head from the Inner Fork Tube. The Seal Head is Loctited into the top of the Fork Tube. Remove the Outer Bushing and use a propane torch to heat the top of the tube to help release the Loctite. Aim the flame towards the Seal Head between the holes. Use gloves (so you don't burn your hand) and the Pin Spanner to remove the Seal Head. Remove the Rod Assembly, pour out the Oil and dispose of it properly. Make sure you remove the three stock plastic Preload Washers at the bottom of the Fork Tube. More than likely they will want to stick to the bottom just with the oil. If you look down the tube and it looks like a big Torx nut a Preload Washer is still in there.
- D5 Slide off the Top-out Spring Washer. Pry the Top-Out Spring off. Use the Shaft Holding Tool (provided) in a Vise to grab the shaft near the top (threaded) end. Remove the stock Valving Assembly.
- D6 Modify the damping rods following the instructions on the last page. You will remove the turned-down 11mm portion as well as shorten the 12mm portion of the rod by 5mm. You will drill and tap the ID to M9x1.0x 18mm deep. (Not a real common thread.)
- D7 Identify the new Compression and Rebound Assemblies by referring to figure 1. Look for the "C" and "R" stamped on the wrench flats. On the Compression Valve notice the shim stack goes on the shaft before the Gold Valve Piston while the Rebound Assembly is reversed.

The Valving Stacks come pre-valved. The standard pre-valved Compression Valving is a combination of cL32 and cH54. The pre-valved Rebound Valving is rL1004, rLX1013 and rH44.

Go to the DVS Digital Valving Search at [racetech.com](http://racetech.com). Select your bike and input the Access Code printed at the top of these instructions. Compare the recommended settings to the pre-valved settings. Change the valving if required.

If no valving change is required, grease the o-ring and insert the stock Adjuster Needle and Spring into the Valving Holder. Use Loctite (supplied), attach the Valving Assembly to the Rod and torque it to 16 ft-lbs (22 NM). Reinstall the stock Top-out Springs and Piston Rings.

⇒ If a valving change is required, go to "**CHANGING VALVING**" otherwise go to "**ASSEMBLY**".

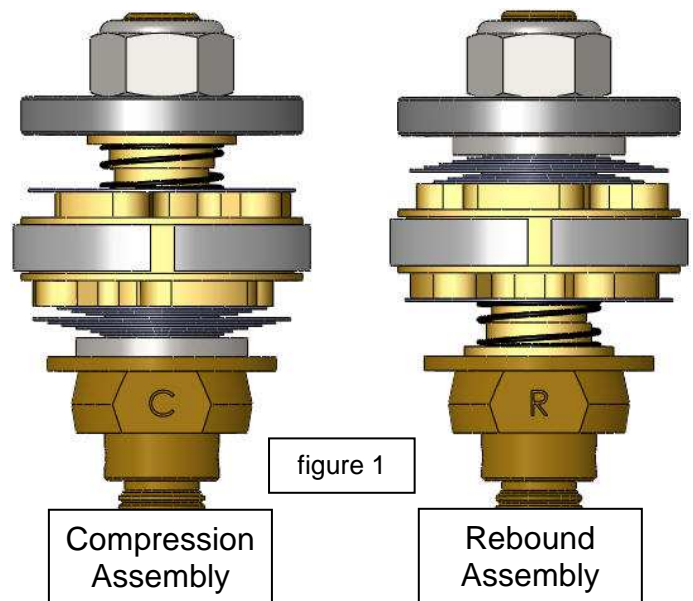

# CHANGING VALVING - Welcome to the wonderful world of Gold Valving.

To obtain your personal Custom Suspension Settings:

1. Log on to [www.racetech.com](http://www.racetech.com)
2. Go to Digital Valving Search (DVS)
3. Input your Access Code (in your kit) when prompted
4. Input your personal specifications
5. Print your DVS Custom Suspension Setup Sheet

If you do not have access to the Internet contact Technical Support at 951.279.6655 for recommendations. Note: The Access Code is good for one bike for a limited-time.

## COMPRESSION LEG (right)

(figure 2)

- C1 Remove the Nut and disassemble the valving stack. Lay out the parts in the order and orientation they were assembled on the shaft.
- C2 Refer to the Compression Valving Charts. Select the DVS recommended Valving Stacks. You will reuse many of the pre-installed shims.
- C3 Begin reassembly by installing the Base Plate. Install the Hi-Speed Compression Stack starting with the smallest diameter shim and ending with the largest.
- C4 Install the Restrictor Stack starting with the smallest diameter shim. **Notice that the largest shim does not cover the ports in the Piston.**
- C5 Install the Gold Valve with the Recess facing up. Install the Check Plate, Check Spring, Stepped Washer and the Spring Seat Washer.
- C6 Install the Nut. Use Loctite (provided) and torque to **48 in-lbs (0.56 kgf-m)**.
- C7 **Inspect the assembled stack.** Hold the valving stack up to the light and look for proper assembly. If there are any problems, disassemble and look for burrs to surface and/or dirt in the valving.

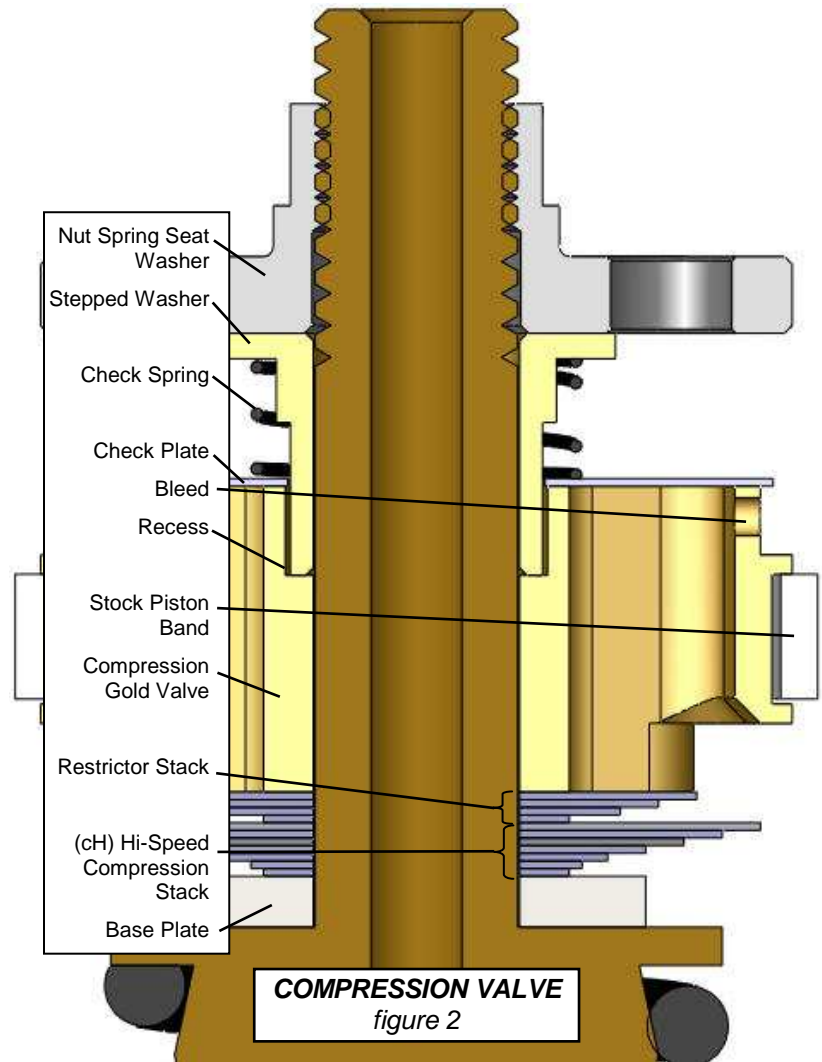

## COMPRESSION VALVING CHART

FCR3128-151216 © P Thede, R Brown

### LO-SPEED COMPRESSION STIFFER →

cL31	cL32	cL33
(1).10x21	(1).10x21	(1).10x21
.10x19	.10x19	.10x19
.10x17	.10x17	.10x17
.10x15	.10x15	.10x15
.10x13	.10x13	.10x13
.10x11	.10x11	.10x11
(2).10x10	.10x10	

### HI-SPEED COMPRESSION STIFFER →

cH50	cH51	cH52	cH53	cH54	cH55	cH56	cH57	cH58*	cH59*
(1).10x27	(1).10x27	(1).10x27	(1).10x27	(1).10x27	(2).10x27	(3).10x27	(4).10x27	(5).10x27	(6).10x27
.10x23	.10x23	.10x23	.10x23	.10x25	.10x25	.10x25	.10x25	.10x25	.10x25
.10x19	.10x19	.10x19	.10x21	.10x23	.10x23	.10x23	.10x23	.10x23	.10x23
.10x15	.10x15	.10x17	.10x19	.10x21	.10x21	.10x21	.10x21	.10x21	.10x21
.10x11	.10x13	.10x15	.10x17	.10x19	.10x19	.10x19	.10x19	.10x19	.10x19
(3).10x10	.10x11	.10x13	.10x15	.10x17	.10x17	.10x17	.10x17	.10x17	.10x17
	(3).10x10	.10x11	.10x13	.10x15	.10x15	.10x15	.10x15	.10x15	.10x15
		(3).10x10	.10x11	.10x13	.10x13	.10x13	.10x13	.10x13	.10x13
			(3).10x10	.10x11	.10x11	.10x11	.10x11	.10x11	.10x11
				(3).10x10	(3).10x10	(3).10x10	(3).10x10	(3).10x10	(3).10x10

NOTE: All measurements are metric (for inches divide by 25.4).

The valving list starts at the piston face and goes towards the base

\* SHIMS NOT PROVIDED IN STANDARD KIT (please call)

# REBOUND LEG (left)

(figure 3)

The Rebound leg is similar to the Compression Leg except the entire valve stack/piston assembly is inverted.

- R1 Remove the Nut and disassemble the valving stack. Lay out the parts in the order and orientation they were assembled on the shaft.
- R2 Refer to the DVS Valving Sheet and Rebound Valving Charts. Select the required Valving Stacks. You will reuse many of the pre-installed shims.
- R3 Begin reassembly by installing the Stepped Washer, Check Spring, Check Plate, and Gold Valve with the recess down against the Stepped Washer.
- R4 Install the Lo-Speed Rebound Stack and the Rebound Crossover. **Unlike the Compression Stack notice that the largest shim does cover the ports in the Piston.**
- R5 Install the Hi-Speed Rebound Stack starting with the largest diameter shim and ending with the smallest.
- R6 Install the Base Plate and Spring Seat Washer.
- R7 Install the Nut. Use Loctite (provided) and torque to 48 in-lbs (0.56 kgf-m).
- R8 *Inspect the assembled stack.* Hold the valving stack up to the light and look for proper assembly. If there are any problems, disassemble and look for burrs to surface and/or dirt in the valving.

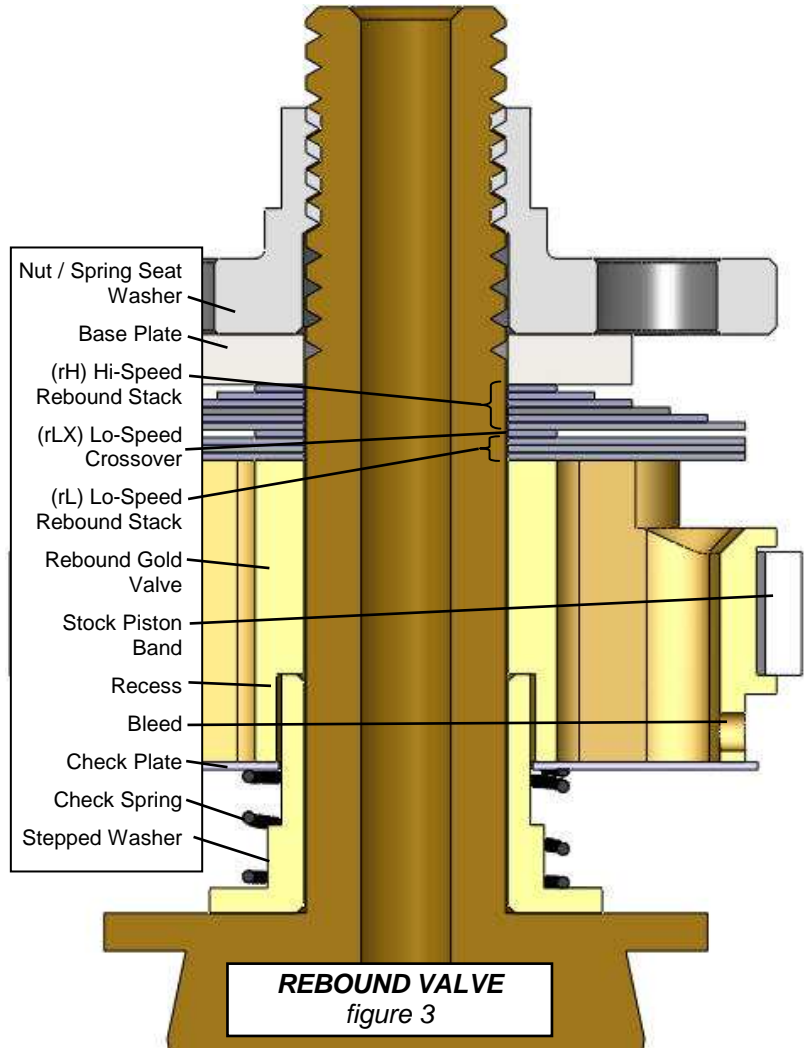

## REBOUND VALVING CHART

FCR3128-151216 © P Thede, R Brown

### LO-SPEED REBOUND SLOWER →

rL1001	rL1002	rL1003	rL1004	rL1005	rL1006	rL1007*	rL1008*	rL1009*	rL1010*
(1).10x27	(2).10x27	(3).10x27	(4).10x27	(5).10x27	(6).10x27	(7).10x27	(8).10x27	(9).10x27	(10).10x27

### LO-SPEED REBOUND CROSSOVER SLOWER →

rLX1011*	rLX1013	rLX1015	rLX1017*
.10x11	.10x13	.10x15	.10x17

### HI-SPEED REBOUND SLOWER →

rH41	rH42	rH43	rH44	rH45	rH46	rH47*	rH48*	rH49*
(1).10x25	(1).10x25	(1).10x25	(1).10x25	(2).10x25	(3).10x25	(4).10x25	(5).10x25	(6).10x25
.10x21	.10x21	.10x21	.10x23	.10x23	.10x23	.10x23	.10x23	.10x23
.10x17	.10x17	.10x19	.10x21	.10x21	.10x21	.10x21	.10x21	.10x21
.10x13	.10x15	.10x17	.10x19	.10x19	.10x19	.10x19	.10x19	.10x19
(2).15x11	.10x13	.10x15	.10x17	.10x17	.10x17	.10x17	.10x17	.10x17
	(2).15x11	.10x13	.10x15	.10x15	.10x15	.10x15	.10x15	.10x15
		(2).15x11	.10x13	.10x13	.10x13	.10x13	.10x13	.10x13
			(2).15x11	(2).15x11	(2).15x11	(2).15x11	(2).15x11	(2).15x11

\* SHIMS NOT PROVIDED IN STANDARD KIT (please call)

Sign up for Race Tech News for the latest developments at [www.racetech.com](http://www.racetech.com).

Valve specs are listed by (QUANTITY) THICKNESS x DIAMETER. A number in parentheses means quantity. If there is no number in parentheses the quantity is one. Example: (2).15x17 means quantity two, 15 hundredths of a millimeter thick by 17 millimeters in diameter.

# ASSEMBLY – make sure all Compression components remain together. (Rebound too)

- A1 **Check the Fork Spring Preload (figure 4).** Make sure the stock Preload Spacers are removed from the bottom of the Fork Tube. If they are not removed the Valving assembly will hit the Internal Reservoir. **Double check that the Reservoir Tube length is 140mm. If it is not CALL RT.** Install the Reservoir Assembly into the chrome Inner Fork Tube first. The Reservoir comes pressurized to 5 psi. Insert the Fork Spring and lightly rest the Compression Damping Rod Assembly on the Fork Spring. **Measure from the end of the chrome Inner Fork Tube down to the Top-out Spring Spacer and subtract the Seal Head Depth (26.5mm). This is the Preload.** It should be 2 to 4mm.
- A2 **If the Preload is negative or not enough** add Preload Spacers and Washers over the Reservoir Tube and under the Spring (figure 5). The Spring must rest on a steel washer not directly on the plastic spacer. Repeat with the Rebound (right) leg.
- A3 Install the Dust Seal, Seal Clip and Oil Seal along with the Seal Washer and Outer Bushing on the Inner Fork Tube. (Note that the Seal Washer probably has been bent into a conical shape on disassembly. If you reverse the washer it will flatten itself during assembly.)
- A4 With the Reservoir and Spring in, fill the Cartridge with Ultra Slick USF05 (5w). Insert the Damping Rod Assembly and stroke it up and down a few times until it is bled. Add Oil up to the bottom of the holes near the top of the Inner Tube. Slowly install the Seal Head, letting the oil overflow into the gap between the Inner and Outer Fork Tube. This procedure completely fills the damping chamber. Use Loctite and torque the Seal Head to 40 ft-lbs.
- A5 Install the Outer Fork Tube and use a Seal Driver to insert, first the Bushing and, then the Oil Seal into the Outer Tube. Install the Seal Clip and the Dust Seal.
- A6 **Install the new Bottom-out Bumper on the Damping Rod. This is critical. If it is not done the Damping Rod will hit the Reservoir.** Install the stock plastic Bottom-out Sleeve.
- A7 Use Loctite on the damping rod thread at the cap. **Screw the Cap onto the Damping Rod until it gently bottoms. Tighten the Jam Nut onto the Cap.**
- A8 Add fork oil to the outer chamber according to the DVS.
- A9 When the forks are put on the bike it is very important to **align the fork tubes.** This is done by first tightening the axle all the way, then the tubes are aligned by pumping the forks up and down with the axle clamp loose. This will line the tubes up so they won't bind. Finally, tighten the axle clamp.
- A10 If you have **any questions** please call Tech Support at 951.279.6655.

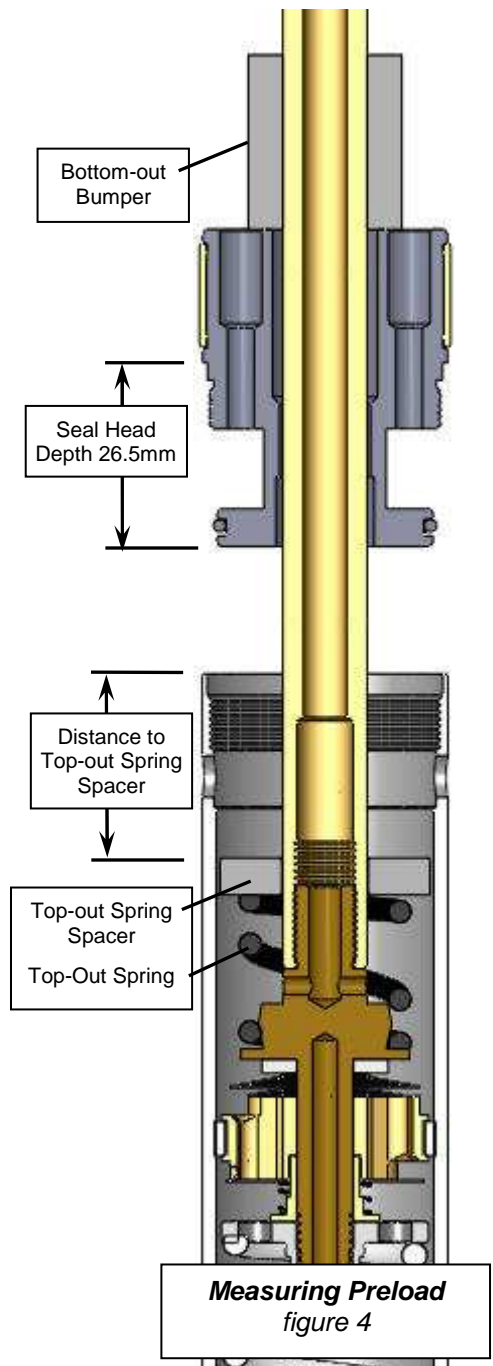

## TUNING NOTES

- Damping depends on vertical wheel velocity, not position in the stroke.
- **If the forks feel too soft all the way through,** increase the compression stack internally.
- **If your valving needs to be stiffer,** move to the right on the Compression Valving chart. If the forks are too firm, go to the left.
- **Spring rate affects ride height and dive.** Typical spring preload should be 2–4mm (.08–.16").
- **Oil level can drastically alter bottoming resistance and only affects the last part of the travel (near bottoming).** If you like the action but the forks bottom too easily, raise your oil level on the outer chamber by 5cc.

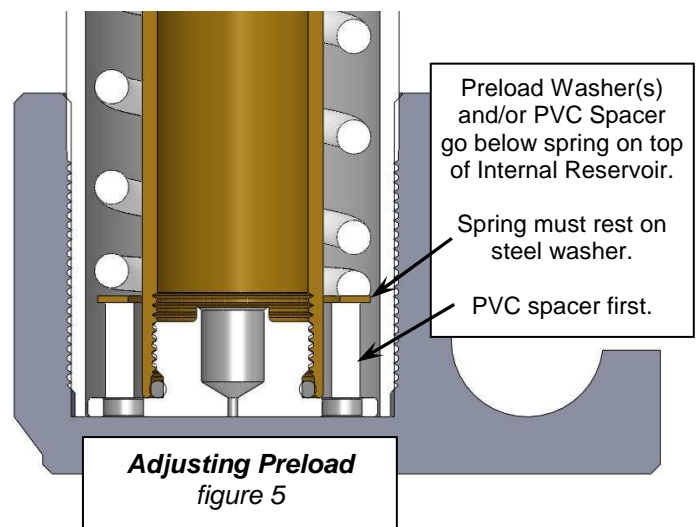

REV.	REVISION DESCRIPTION	DATE	APPROVED

MOD TO INSTALL FMGV 3102C KIT  
DAMPING ROD MUST BE SHORTENED  
FROM 305 (STOCK) TO 300

IF THIS IS NOT DONE CORRECTLY THE  
DAMPING ROD WILL HIT THE  
INTERNAL RESERVOIR

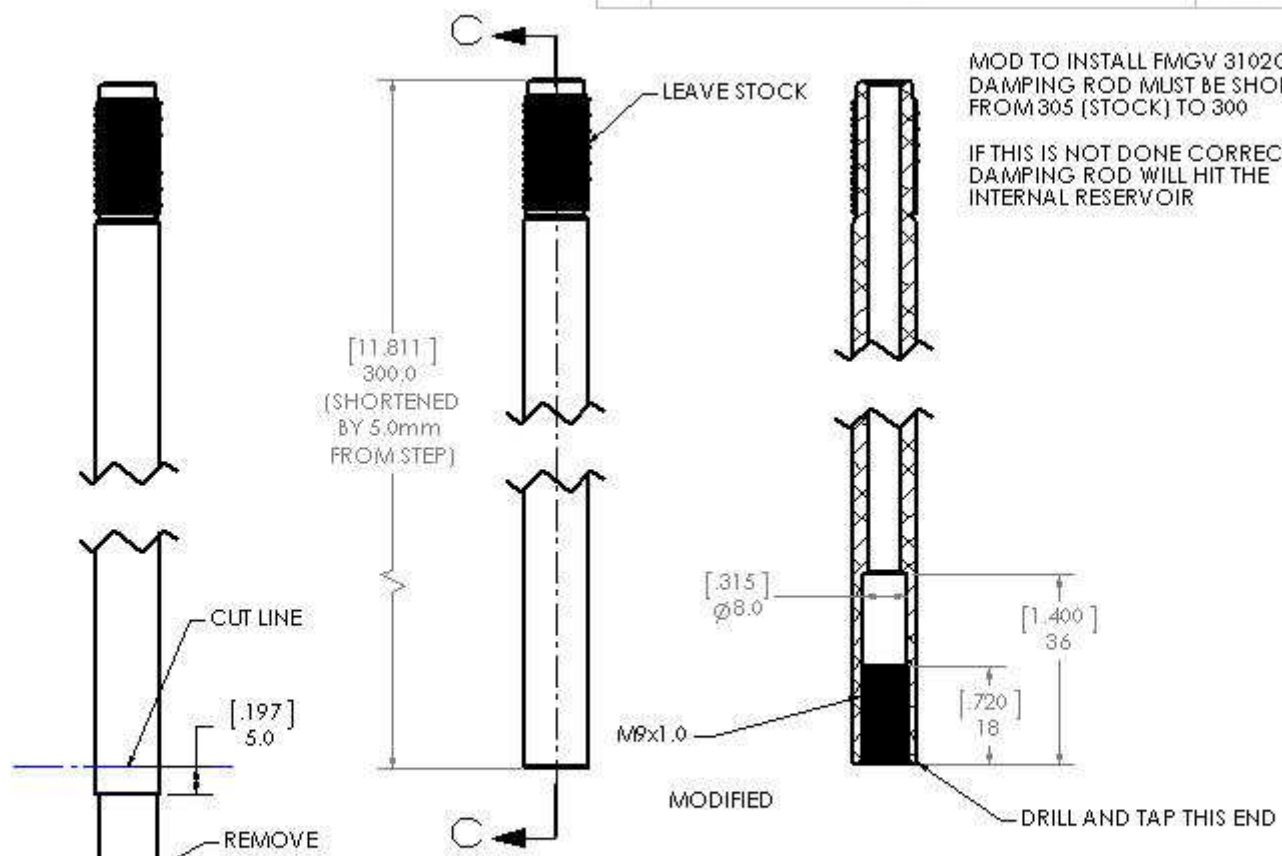

STOCK

DIMENSIONS 0 .125 0.00 .005 0.00 .005	DIMENSIONS ARE IN MILLIMETERS (M) UNLESS SPECIFIED	THE INFORMATION CONTAINED IN THIS DRAWING IS THE SOLE PROPERTY OF RACE TECH. ANY REPRODUCTION IN PART OR WHOLE WITHOUT WRITTEN PERMISSION IS PROHIBITED.
MATERIAL:	DATE:	
NUMBER:	APPROVED:	
CODE:	VERSION:	

<b>RACE TECH</b>		1501 Pomona Road, Corona, CA 92880	
		951279.6655 fax:951279.7171	
<b>CART DAMPING ROD - 12 x 300 KTM 50SX MOD</b>			
SCALE:	PART NO FRR 12 M1220502 STK	FINISH:	DWG NO
SHEET 1 OF 1	REV FRR 1220502 MOD DAMP ROD KTM 50SX 2012 addrw		2050
			REV
			*