

RACE TECH

1501 Pomona Rd, Corona, CA 92880 • 951.279.6655 • fax 951.279.7171 • www.racetech.com

SWINGARM GEOMETRY for CUSTOM SHOCKS

<SwingarmGeometry.doc> P Thede © 4-28-09

Name _____
 Address _____
 City _____ St _____ Zip _____ Country _____
 Phone _____ Email _____
 Year _____ Make _____ Model _____
 Bike Weight _____ lbs / kg Rider Weight (without gear) _____ Additional Unusual Gear Weight _____
 Non-standard Vehicles - Front/Rear LaidenWeight Bias (rider on board) _____
 Type of Riding _____ Skill Level _____

Geometry - All measurements in millimeters please.

- A _____ Swingarm Pivot to Ground (bike level)
- B _____ Rear Axle to Ground (bike level)
- C _____ Swingarm Pivot to Upper Shock Mount
- D _____ Swingarm Pivot to Lower Shock Mount
- E _____ Extended Shock Length (fully extended)
- F _____ Swingarm Length (swingarm pivot to axle in middle position)
- G _____ Lower Shock Mount to Swingarm Centerline (perpendicular to swingarm axis)

- H _____ Collapsed Shock Length (fully collapsed, no bumper – must have tire to fender/frame clearance)
- I _____ Upper Eyelet Bolt Diameter
- J _____ Upper Eyelet Width
- K _____ Lower Eyelet Bolt Diameter
- * Lower Eyelet or Clevis (circle)
- L _____ Lower Eyelet/Clevis Width
- M _____ Maximum Wheel Travel Allowed

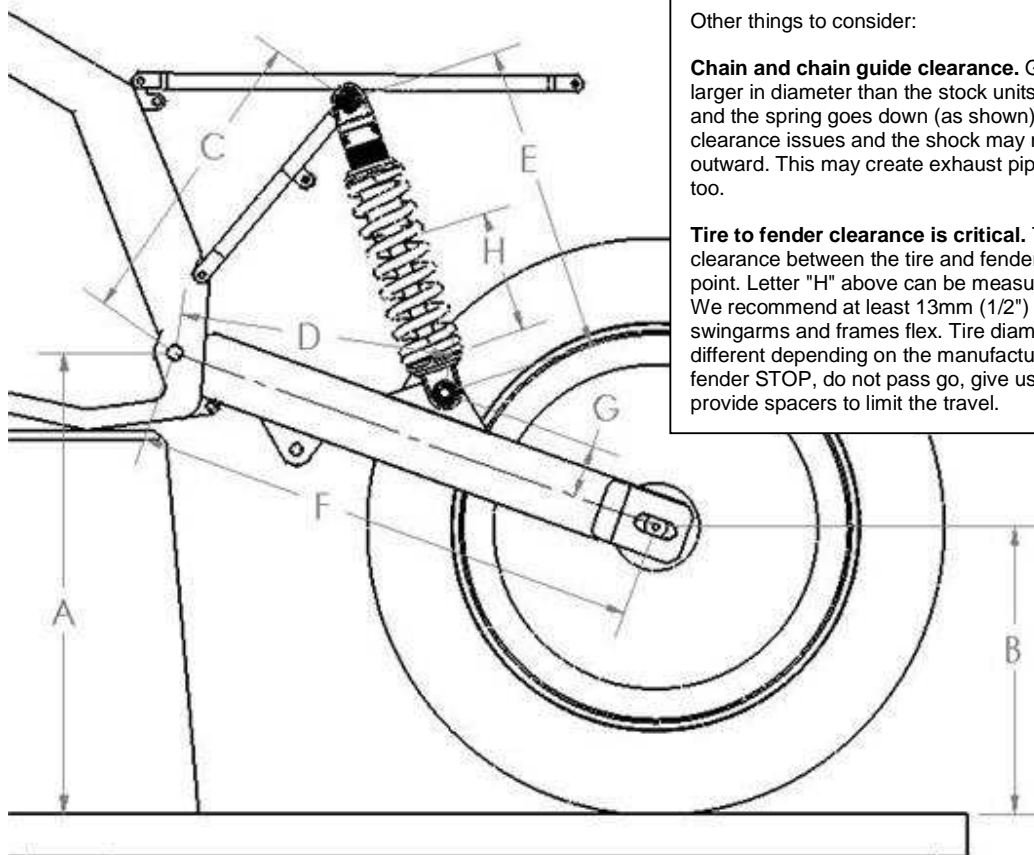

Other things to consider:

Chain and chain guide clearance. G3-S Shocks are often larger in diameter than the stock units. The body end goes up and the spring goes down (as shown). This can cause clearance issues and the shock may need to be spaced outward. This may create exhaust pipe clearance problems too.

Tire to fender clearance is critical. There MUST always be clearance between the tire and fender at the fully collapsed point. Letter "H" above can be measured without the shock on. We recommend at least 13mm (1/2") clearance minimum as swingarms and frames flex. Tire diameters will also be different depending on the manufacturer. If the tire hits the fender STOP, do not pass go, give us a call and we will provide spacers to limit the travel.