

RACE TECH

1501 Pomona Rd, Corona, CA 92880 • 951.279.6655 • racetech.com

FK code

FORK GOLD VALVE INSTALLATION - DIRT 28 x 6mm

<IP FMGV 2820w.doc> FMGV 2820, FMGV 2870 P Thede © 12.5.15

TOOLS REQUIRED: (In addition to those required for fork disassembly.) In-lb torque wrench that accurately measures 0 to 50 in-lbs (0.58 kgf-m), 10mm wrench, Fine flat file, Hi-Strength Loctite (included), Metric calipers and micrometer.

NOTE: Many riders require different fork springs. Please consult www.racetech.com or call Race Tech.

CAUTION! The threads can be damaged without using extreme care. Some are made out of aluminum and strip easily.

DISASSEMBLY

- D1 **Completely disassemble and clean your front forks. If you are unfamiliar with this process, STOP! Do not proceed. Seek out a qualified suspension technician to complete the installation**
- D2 **Remove the nut. On SHOWA forks only** when disassembling the compression valve for the first time, **the threads above the nut must be filed off flat.** Lightly deburr the end of the threads.
- D3 **Disassemble the valving stack.** Lay out the pieces in the order they come off the shaft. Clean and inspect all the original parts. Be careful to maintain the original order and orientation of the parts. (You may need some of the original valving for spacing purposes, do not discard.)

VALVING SELECTION

- V1 **To obtain custom suspension and valving settings log on to www.racetech.com, go to Digital Valving Search, insert your Access Code (printed on the top of the first page), input your personal specifications and print the custom setup information. If you do not have access to the web contact our Technical Support Hotline 951.279.6655 for recommendations. Note: The Access Code is good for one limited-time use.**
- V2 **Once you have selected your valving begin assembling the valve.** (Refer to figure 1 for Showa, figure 2 for WP) Place the original Base Plate (if used) on the shaft of the compression valve. **For SHOWA only, add the 4mm thick Base Plate that is supplied with the kit.**
- V2a **Single Stage Stacks** (figure 3) - A Single Stage Stack is a two-part stack made up of a combination of a **Lo-Speed Stack** and a **Hi-Speed Stack with NO Crossover**. Put the valving on the shaft in the order listed, starting with the smallest diameter shim of the Hi-Speed Stack. Then the Lo-Speed Stack gets placed on top of the Hi-Speed Stack. **You will not use a Crossover.**
- V2b **Two Stage Stacks** (figure 1) - For Two Stage Stacks the total valving stack is made up of a combination of a **Lo-Speed Stack, a Crossover**

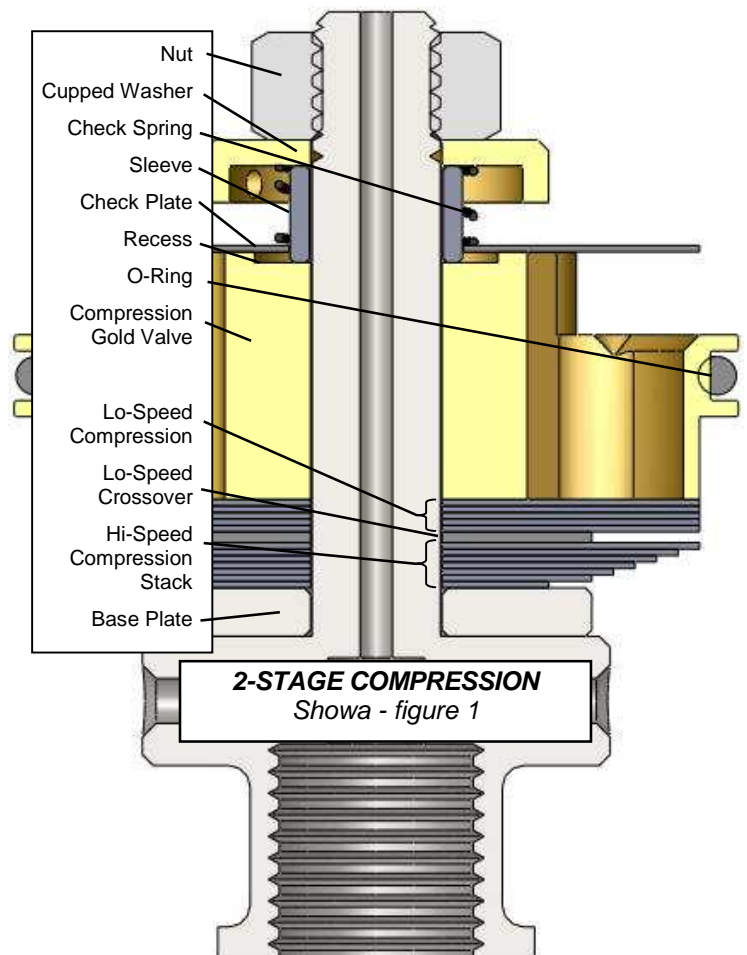

and a Hi-Speed Stack. Put the valving on the shaft in the order listed, starting with the smallest diameter shim of the Hi-Speed Stack. Then the Lo-Speed Crossover gets placed on top of the Hi-Speed Stack, then the Lo-Speed Stack ends up closest to the Gold Valve. (see figure 1 or 2 - your exact configuration may look slightly different.)

V3 Make sure the o-ring is on the Gold Valve. **Place the Gold Valve on the shaft** with the recess on the piston facing away from the valving (up).

V4a **SHOWA** (figure 1) - **Place the check valve sleeve on the shaft**, then the check valve plate (*large ID washer*) and the spring. Be sure the sleeve fits into the recess in the piston and the plate is free.

Put the spring cup on the shaft dished down. This is a critical part of the installation. You must be very sure that the spring cup straddles the step at the end of the threads. If it does not one of two things will happen. Either the nut will tighten down on the step instead of the valving causing it to come loose or not damp properly. Or the spring cup will catch on the step and not tighten properly, also creating the possibility that the valve will loosen. **To get the proper total valve stack thickness you may place some of the original shims on the shaft below the base plate. Be sure that the spring cup is straddling the step and the nut has full engagement!!!**

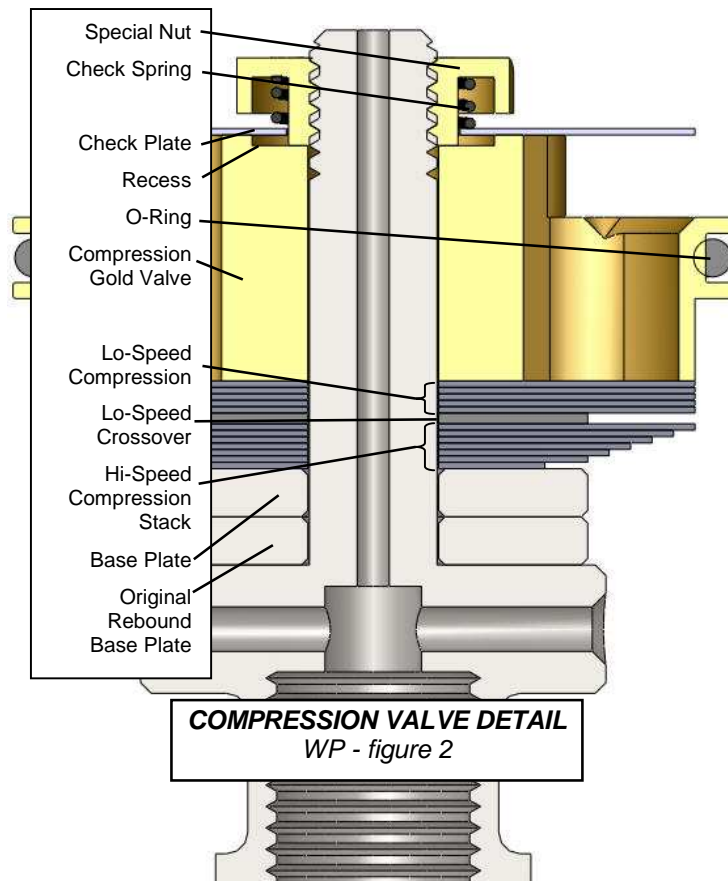

V4b **WP** (figure 2) – Place the check spring and the check valve plate (*large ID washer*) on the nut. **Make sure the nut does not run out of threads before it tightens on the valving.** If it does it may destroy the compression body. **Screw the nut assembly onto the shaft.** Be sure the sleeve fits into the recess in the piston and the check valve plate is free.

V5 **Check to see that the check valve plate (*large ID washer*) is free** and can move up and down against the spring.

V6 **CAUTION! The threads can be damaged without extreme care. Some are made out of aluminum and strip easily. To install the nut you must use Loctite. The 6mm nut must be torqued with a torque wrench to 30 in-lbs (2.5 ft-lbs or 0.35 kgf-m), NO MORE! Do not take this step lightly.**

V7 **Check your work.** For two stage stacks, hold the compression stack up to the light and look for the gap at the cross-over between the low speed and high speed stack (*the small shim near the top of the stack*). This gap should be visible, if it isn't, disassemble the stack and look for burrs to surface and/or dirt in the valving. Reassemble and check again.

ASSEMBLY – WP and Showa

A1 **Reassemble the forks according to the procedure in your manual.** Torque the compression valve body to manufacturers specs. For most forks this is 43 to 60 ft-lbs (58 - 82 NM). Consult owners manual for specs. Bleed the cartridge and set the oil level using Ultra Slick USF-05 (5w).

NOTE: WP 46mm forks do not have a bleed hole in the inner (chrome) tube. They require special care to set the oil level. There is a space between the inner and outer tube and without a bleed hole there is no way to know how much oil is in this space. Before setting the level extend the outer tube all the way, this will dump all the oil from this space into the inner tube. This may call for higher oil level settings than the manufacturers recommend.

A2 Use Loctite on the damping rod threads at the cap and **torque it to manufacturers specs** (typically 16 to 21 ft-lbs [21.7 – 28.5 NM]). Consult owners manual for specs.

A3 Adjust the compression and rebound adjusters, spring preload, and oil level according to the Digital Valving Search Setup Sheet.

A4 **Install the forks on the bike.** When the forks are put on the bike it is very important to align the fork tubes. This is done by first tightening the axle all the way, then the tubes are aligned by pumping the forks up and down with the right-hand axle clamp loose. This will line the tubes up so they won't bind. Finally, tighten the axle clamp.

A5 **If you have any questions** please call our Technical Support Hotline at 951.279.6655. Feel free to experiment and please call if you need us. Have fun!

TUNING NOTES

- **Damping depends on vertical wheel velocity, not position in the stroke.**
- **If the forks feel too soft all the way through,** increase compression damping with the external adjuster. If that is not enough, change the compression stack internally.
- **The compression damping adjuster** controls the lowest speed damping and affects the entire range. NOTE: The closer to maximum damping (full clockwise) the more effect one click makes. In other words going from 3 to 2 out has a lot more effect than going from 14 to 13. Adjusters are numbered from all the way clockwise (the slowest or firmest setting).
- **Spring rate affects ride height, dive and bottoming.** Typical spring preload should be 3-5mm (0.1–0.2").
- **Oil level can drastically alter bottoming resistance and only affects the last part of the travel** (near bottoming). If you like the action but the forks bottom too easily, raise your oil level by 10cc or 10mm.

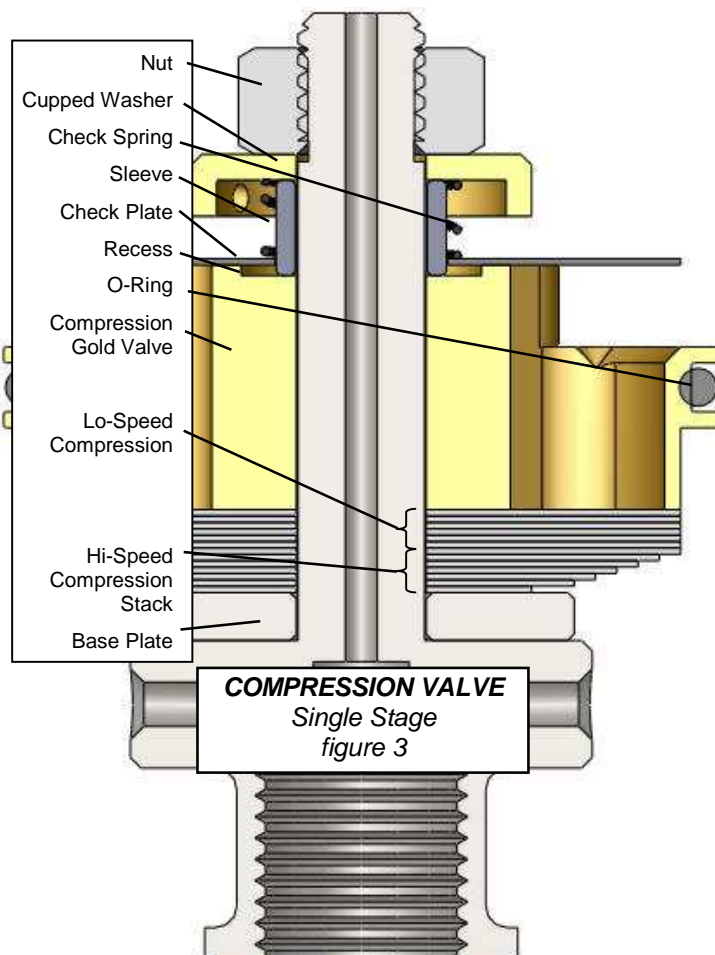

BUILDING the VALVING STACK - DIRT 28x6mm

Welcome to the wonderful world of Gold Valving. To obtain your personal Custom Suspension Settings:

1. Go to Digital Valving Search (DVS)
2. Input your Access Code (on top of page 1) when prompted
3. Input your personal specifications
4. Print your Digital Valving Search (DVS) Setup Sheet

If you do not have access to the Internet contact our Technical Support Hotline 951.279.6655 for recommendations. Note: The Access Code is good for one bike, limited-time use.

Once you have your valving settings, build your valving stacks.

Single Stage - made up of a Lo-Speed Stack and a Hi-Speed Stack. You will not use a Lo-Speed Crossover.

Two Stage - made up of a Lo-Speed Stack, Lo-Speed Crossover and a Hi-Speed Stack.

Example Single Stage (figure 3)

Starting from the Gold Valve piston face:

Lo-Speed Stack

(4) .15x24

Crossover – none

Hi-Speed Stack

- (1) .10x24
- (1) .10x22
- (1) .10x20
- (1) .10x18
- (1) .10x16
- (1) .10x15
- (1) .10x14
- (1) .10x13
- (1) .10x12

Example Two Stage (figure 1&2)

Starting from the Gold Valve piston face:

Lo-Speed Stack

(4) .15x24

Crossover

(1) .10x16

Hi-Speed Stack

- (1) .10x24
- (1) .10x22
- (1) .10x20
- (1) .10x18
- (1) .10x16
- (1) .10x15
- (1) .10x14
- (1) .10x13
- (1) .10x12

OIL LEVEL, EXTERNAL ADJUSTERS, SPRING RATE, and PRELOAD are listed on the DVS on racetech.com.

NOTE: All measurements are metric (for inches divide by 25.4). The valving list starts at the piston face and goes towards the base plate. Valve specs are listed by (QUANTITY) THICKNESS x DIAMETER. A number in parentheses means quantity. If there is no number in parenthesis the quantity is one. Example: (2).15x30 means quantity two, 15 hundredths of a millimeter thick by 30 millimeters in diameter.

