

REV.	REVISION DESCRIPTION	REDRAWN	APPROVED
*	*	*	*

MOD FOR FPPR HQ35 PISTON RING  
MUST HEAT AND SQUEEZE SPRING END COIL TO  $\phi 17.5$   
USE FPEV AD3304, FEGV 3301 EMULATORS

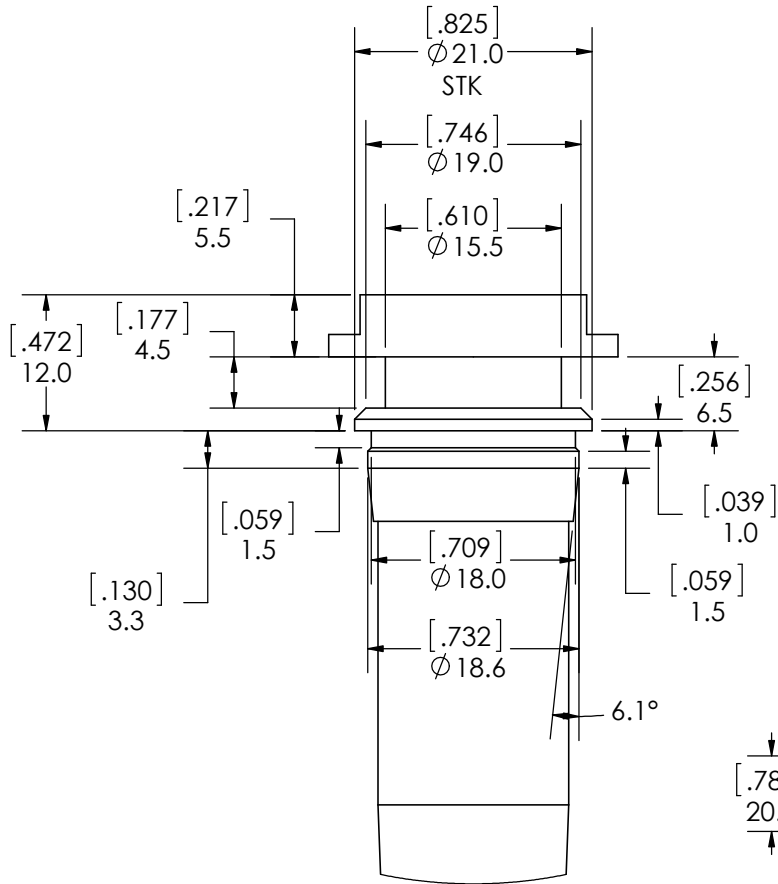

DETAIL B  
SCALE 1.5 : 1

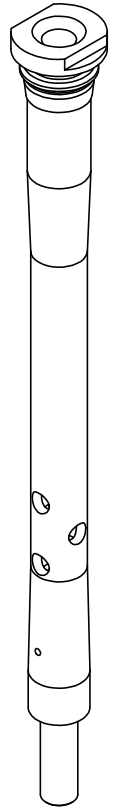
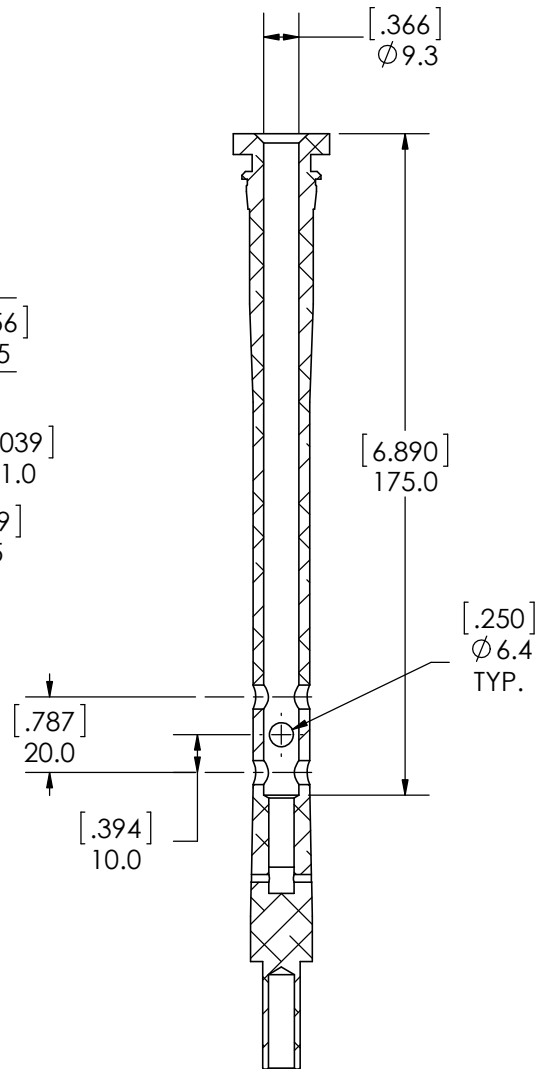

SECTION A-A

TOLERANCES: Dimensions are in MILLIMETERS [IN] unless specified  
0 =  $\pm .5$   
0.0 =  $\pm .1$   
0.00 =  $\pm .05$

The information contained in this drawing is the sole property of Race Tech. Any reproduction in part or whole without written permission is prohibited.

**RACE TECH**

1501 Pomona Road, Corona, CA 92880  
951.279.6655 fax: 951.279.7171

DAMPING ROD MOD - 35mm HUSKY 1974

MATERIAL: ALUMINUM	DRAWN: PT 3-6-15	SCALE:1:2	PART NO. FPDR 35HUSQ1974	FINISHED P/N *	DWG. NO. 2350	REV. *
FINISH: *	APPROVED: *	SHEET 1 OF 1	FILE FPDR 35HUSQ1974 HUSKY EARLY STK-MOD.slddrw			
COLOR: *	ECR#: *					